

**MANUAL FOR
COMMUTATION CONTROL UNIT
TMC_2**



DESCRIPTION

The generator control unit is a device that enables automatic commutation between a line-network source and a generator.

When the main network fails, the control unit supplies consent for the generator to start up.

Once the generator is running, and voltage and frequency are stable within the established limits, the commutation is automatically commanded to the generator.

Once the power from the main network returns, also automatically, the commutation is commanded to the network and therefore the generator is stopped.

ELECTRICAL SPECIFICATIONS

Feed voltage (separated in a galvanic manner)	9 - 30VDC
Type of measurable and selectable voltages	208 1ph -208 3ph-230 1ph - 230 3ph 400 1ph - 400 3ph - 440 1ph - 440 3ph
Nominal frequency	45-65 Hz
Voltage range measured on the generator side	0÷500VAC
Voltage range measured on the network side	0÷500VAC
Accuracy in measurements	± 2%
11-12-14 alarm relay contact	8A 250V max
Ag1-Ag2-Ar1-Ar2 auxiliary remote control switch contact control	8 ÷ 36VDC
Sg1 Sg2 Generator starter contact	5A 10÷30VDC
TR1 – TR2 Network remote control switch contact	5A 230VAC
TG1 – TG2 Generator remote control switch contact	5A 230VAC

TYPES OF OPERATION

The device can be operated in two different modes: *Manual* or *Automatic*.

When it is started up, it automatically goes into one of these two modes, depending on the setting established by parameter P13.

Manual Operation

In *Manual* mode, the intervention limits and the waiting times for commutations are disengaged.

The generator Start and Stop controls are controlled by means of the **GEN/Start/Stop** button.

The commutation of the charge is carried out by means of the key-operated switch and the corresponding white LEDs indicate the status. Furthermore, the corresponding AG and AR, green LEDs, will follow the status of the auxiliary contacts on the generator and network line remote control switches (if assembled and connected).

There is also an available option that makes it possible to display the Network or Generator voltages, to be selected by means of the **SEL/MIS** button.

With the arrow buttons pointing upwards or downwards, one chooses the cyclic phase to be displayed and the corresponding LEDs on the right hand side of the display indicate the phase that is being measured.

From *Manual* mode one can change over to *Automatic* mode and vice versa by pressing the **MAN/AUT** button.

Two separate LEDs indicate the Network or the Generator; when, in the Generator mode, the start contact is not enabled, the display shows the word "**OFF**", indicating that the generator is off.

As soon as the motor ignition contact is activated, the word "**OFF**" is replaced with the corresponding measurements.

!!! In manual mode no alarms are detected and/or managed!!!

Automatic Operation

In *Automatic* mode the control functions are delegated exclusively to the software.

In this case, it is therefore not possible to start or stop the Generator using the buttons on the front panel, and even the functions controlled by the key are disengaged.

In this mode, the display follows the status of the system, if it is connected to the Network and all the voltages are correct, the LEDs and the display will show the Network voltages.

Once the commutation from Network to Generator takes place, the displays follow the new mode and subsequently will show the Generator's parameters.

Once the Network is restored, and therefore commutation to the previous status takes place, the displays will behave in accordance.

At any time, there is the possibility of carrying out manual measurements by means of the **SEL/MIS** buttons and of the arrow buttons pointing up or down to choose the cyclic phases.

The phases are controlled individually, therefore the lack of a single Network phase causes the initiation of the commutation sequence. In the same way, the lack of a single phase of the Generator implies the alarm intervention.

Only in the three-phase systems, provision is made for an asymmetry control by means of parameters set in P16 and P17 and the corresponding error signal ER3.

As far as the frequency is concerned, this is controlled only on the Generator between phases R/G and S/G, or R/G and T/G.

In *Automatic* mode the following alarms and signals are managed:

Passing the Minimum or Maximum Network voltage limits

LO (min) or **HI** (max) flash on the display in Network mode.

The control unit starts the line commutation sequence.

The commutation sequence takes place following these steps:

- 1) Generator ignition delay.
- 2) Generator verification delay.
- 3) Delay in commutation from line to charge.

If during step 2 the Generator is found to be **OK**, the charge commutation sequence continues to the end, moving from the mains to the generator.

If, at the end of step 2 (**P8**), the generator voltage and frequency are not **OK**, the control unit signals one of the following alarms:

Er1: The Generator voltage is higher/lower than the set limits.

Er2: The Generator frequency is higher/lower than the set limits.

Passing the Minimum or Maximum Generator voltage limits (after commutation)

After the commutation from Network to Generator, a software filter is enabled (**P15**), which makes it possible to mask the alarms during the entire period in which the generator is operating, thus allowing it to follow all the possible charge variations without the control unit giving false alarms due to possible variations.

If a voltage variation occurs, or persists beyond the set time (**P15**), the corresponding alarms will be reactivated:

Er1: The Generator voltage is higher/lower than the set limits.

Er2: The Generator frequency is higher/lower than the set limits.

As a result of the error the Generator is shut down.

In order to eliminate the two alarm signals it is necessary to reset the system by pressing the **MAN/AUT** button.

At this point, the control unit repositions the charge in the condition set by parameter **P18** and once again attempts the sequence to start up the Generator.

Passing the limit in asymmetry difference (only on three-phase system)

In this case, **LSI** flashes on the display in Network mode.

The control unit starts the line commutation sequence.

The commutation sequence takes place in steps:

- 1) Generator ignition delay.
- 2) Generator verification delay.
- 3) Delay in commutation from line to charge.

If during step 2 the Generator is found to be **OK**, the charge commutation sequence continues to the end, moving from the mains to the generator.

If, at the end of step 2 (**P17**), the value of the generator voltage is asymmetric, the control unit gives the following alarm:

Er4: The Generator symmetry is higher or lower than the set limits.

As a result of the error the Generator is shut down.

In order to eliminate the alarm signal it is necessary to reset the system by pressing the **MAN/AUT** button. The control unit repositions the charge on the main line and tries the commutation sequence again.

Re-establishment of line symmetry within the limits

If the network voltage returns to within the established parameters, the control unit carries out the line restoration sequence:

- 1) Delay for commutation from Generator to Network **P10** (as set).
- 2) Delay for turning the Generator off **P11** (as set).

Closed auxiliary contact or voltage failure error

This alarm is enabled by means of parameter **P20**, which has three sub-functions:

- 1) Disable function
- 2) Enable function:

By means of LG-LR voltage control, if the voltage after the remote control switch, both for the Network and for the Generator, fails, this is signalled with the corresponding white LED turning off.

The following appears on the display:

Er3: Closed auxiliary contact or voltage failure error.

- 3) Enable function by means of auxiliary contact control:

To use this function it is necessary to assemble an auxiliary contact for each remote control switch and to connect it to the provided inputs AG1-2 AR1-2 (connection present at low voltage).

In the case in which the auxiliary contacts are not closed, this means that there is a problem with the remote control switches, and the corresponding green LED and display turn off:

Er3: Closed auxiliary contact or voltage failure error.

In any case, as a result of the error the Generator is shut down.

In order to eliminate the alarm signal it is necessary to reset the system by pressing the **MAN/AUT** button. The control unit repositions the charge in the condition set by parameter **P18** and once again attempts the sequence to start up the Generator.

Re-establishment of line voltage within the minimum or maximum limits

If the network voltage returns to within the established parameters, the device carries out the line restoration sequence:

- 1) Delay for commutation from Generator to Network **P10** (as set).
- 2) Delay for turning the Generator off **P11** (as set).

Enabling the alarm relay:

If one of the aforementioned errors is caused (Er1-Er2-Er3-Er4), the alarm relay is enabled (contacts 11-12-14).

The relay can be set as follows by means of parameter **P19**.

- 1) Relay normally deactivated (active on alarm).
- 2) Relay normally activated (deactivated on alarm).
- 3) Relay always deactivated

The commutations from Network to Generator and vice versa are equipped with an inter-blocking time between the remote control switches equal to 500 ms.

Commutation from *Manual* to *Automatic* and vice versa is possible only if block mode **P14** is not active.

In the case in which the block mode is active, the **MAN/AUT** button can only be used to cancel a possible alarm (in automatic mode).

Parameter **P13** determines, on starting up of the control unit, its *Automatic* or *Manual* status.

PROGRAMMING

Programming can be carried out in any status, including alarm status.

This is made possible with the introduction of **P14** for mode blocking.

If the function is activated in *Automatic* mode, the rearming time for the device in case of alarm may be less than the time required for access to programming, making this action impossible.

Simultaneously press the up and down arrow keys for more than 5 seconds: "**IPr**" (start programming) appears on the display.

By releasing the up and down arrow keys, the display commutates to "**P01**" (parameter 01).

Using the up and down arrow keys, pressed individually, one obtains the cyclic selection of parameters **P01..P20..P01..P20** (parameter display mode).

Once you have selected the parameter to be modified, press the **SEL/MIS** button: the display shows the value of the parameter currently memorised (*). (Value display mode)

By means of the up and down arrow buttons, pressed individually, one can select the desired value.

In order to accelerate the programming functions for certain parameters, hold the corresponding key down and the value automatically increases/decreases by 1 unit every 500 ms. After the first 10 increases, the auto-increase speed rises to 5 units per second, and continuing beyond 30 increases, the speed accelerates again to 10 units per second.

By releasing the key you restore the normal selection mode.

To return to parameter selection, press the "**SEL/MIS**" button.

Proceed to programme all the parameters.

After programming, to exit and save the data, proceed as follows:

In **P01-P20** parameter display mode, press the up and down arrow keys simultaneously. The display shows "**EPr**" (end programming).

After you let go of the up and down arrow buttons, the display will continue to show the monitored phase for about 3 seconds:

"**L23.**" For monophase 230 V (the decimal point on the unit figure indicates a monophase system).

"**L23**" for 230 V three-phase (no decimal point).

"**L40**" for 400 V three-phase (no decimal point).

"**L44**" for 440 V three-phase (no decimal point).

This parameter is also displayed when the control unit is turned on, and indicates the type of setting.

Please note:

(*) When changing the **P01** parameter concerning the type of phase to be monitored, the set minimum and maximum commutation limits are replaced by default with standard values equal to 50% of the settable range for the chosen type of line, for example:

Selected line 230 V monophase: **P01=230V**

- Minimum voltage limit 212 V: **P03=212V**

- Maximum voltage limit 243 V: **P04=243V**

New selected line 400 V three-phase: **P01=400V**

- New minimum voltage limit: **P03=360V** $(400V+320V)/2=360V$

- New maximum voltage limit: **P04=440V** $(400V+480V)/2=440V$

If the initial type of line is selected again at a later moment, that is to say **P01=230V**, the original parameters are loaded again.

The same goes for the minimum and maximum voltage limits for the Generator.

The default parameters can also be varied as requested.

The commutation and delay time values are not influenced, so they remain the same.

In order to differentiate the representation of the values between 230 V monophase and 230 V three-phase, the decimal point is displayed on the unit figure (in the first case, both in programming mode and in the normal display.

TABLE OF SETTABLE PARAMETERS AND LIMITS

Parameter	Selected function	Range	Description
P01	Network Type (Vn).	230-230-400-440	Type of network to be controlled.
P02	Frequency.	50-60	Nominal network frequency: 50 or 60 Hz.
P03	Minimum Line Voltage	Vn....-20%	Minimum line voltage. The higher limit is set at Vnom – 4 V in order to avoid false commutations.
P04	Maximum Line Voltage	Vn... +20%	Maximum line voltage. The higher limit is set at Vnom + 4 V in order to avoid false commutations. For 440 Vac: range = +10%
P05	Minimum Generator Voltage	Vn....-20%	Minimum generator voltage. The higher limit is set at Vnom – 4 V in order to avoid false commutations.
P06	Maximum Generator Voltage	Vn... +20%	Maximum generator voltage. The higher limit is set at Vnom + 4 V in order to avoid false commutations. For 440 Vac: range = +10%
P07	Generator Start-up Delay	1...600s	T1 delay in identification of the line malfunction on starting up the generator.
P08	Generator Delay Validation OK.	0...600s	T2 delay in starting up the generator to generator OK verification.
P09	Line/Generator Commutation Delay	1...240s	T3 delay from identification of stable generator to commutation of the charge to the generator.
P10	Generator/Line Commutation Delay	1...240s	T4 delay from identification of network malfunction alarm restoration to commutation of the charge to the line.
P11	Generator Shutdown Delay	1...240s	T5 delay from the commutation of the charge from the generator to the line to the shutdown of the generator.
P12	Frequency Tolerance Limit	1...9 Hz	Permitted generator frequency tolerance.
P13	Auto/Manual Mode	0=manual 1=automatic	Control unit's operational mode when started up.
P14	"LOCK" mode	1=unlocked 0=locked	Manual/automatic commutation and vice versa lock mode.
P15	Alarm mask	0...60sec	Alarm masking time after commutation from network to generator.
P16	Phase asymmetry limit alarm (only on three-phase system)	10...40V	Voltage which, beyond the set value, signals an asymmetry error.
P17	Asymmetry intervention delay (only on three-phase system)	1...30sec	T6 delay in starting up the generator to generator OK verification.
P18	Enable line connection	0=disabled 1=enabled	Function for reconnecting to the network if the generator is not working properly.
P19	Alarm Relay Mode	1=relay off on all on 2=relay on all off 3= relay disabled	Alarm relay operation mode
P20	Acquisition for Er3 alarm	1=disabled 2 = LR LG signals 3 = AR AG signals	Signal acquisition mode for Er3 error.

- The values of the intervention limits can be set by steps of 1 V.
- The values of the delay times can be set in steps of 1 second.
- The generator frequency tolerance limit value can be set in steps of 1 Hz.

SPECIAL FUNCTIONS

Eeprom data protection function

If the auxiliary feed happens to fail during the parameter memorisation phase, the parameters may be corrupted. Anyway, when starting up the device verifies the correctness of the data on Eeprom.

If the parameters are found to be corrupt, the programme locks and the display shows the 'EEE' error mode. The system must therefore necessarily restore the default data.

To restore the default data:

- 1- In error mode press and release the "SEL" button.
- 2- The display changes to "rrr". The programme is still locked, but the default data has been loaded.
- 3- It is necessary to remove and restore the auxiliary feed.
- 4- By holding down the up and down arrow keys during the start-up procedure, you can gain access to the programming mode and reset the desired values.
- 5- If the control unit is not programmed again, it will start up anyway, but with the following factory settings:

- P01** "400" Three-phase 400 V Line.
P02 " 50" Network frequency 50 Hz.
P03 "340" Lower Network voltage limit (V).

P04	“440“	Upper Network voltage limit (V).
P05	“340“	Lower Generator voltage limit (V).
P06	“440“	Upper Generator voltage limit (V).
P07	“ 5“	Generator Start-up Delay (seconds).
P08	“120“	Generator OK confirmation delay.
P09	“ 5“	Network/Generator commutation delay (seconds).
P10	“ 10“	Generator/Network commutation delay (seconds).
P11	“ 30“	Generator Shutdown Delay (seconds).
P12	“ 5“	Generator Frequency Tolerance Limit (Hz).
P13	“ 0“	Automatic operation mode.
P14	“ 1“	“Locking” function excluded.
P15	“ 3“	Network/Generator commutation alarm masking.
P16	“ 20“	Phase symmetry voltage limit (V)
P17	“ 1 “	Symmetry alarm intervention delay (s)
P18	“ 0 “	Network reconnection relay disabled
P19	“ 1 “	Alarm relay at rest on excited alarm.
P20	“ 1 “	Signal acquisition by means of LR and LG signals.

PROGRAMMING IN DETAIL

Up and **down** arrow buttons pressed for $t > 5$ seconds → Display: **IPr** for $t = 2$ seconds or until the keys are released.
Display: **P01**

Up and **Down** arrow keys held down → Display: **P01 - P15 - P01 - P15**
SEL pressed → Display: **Parameter value.**

Up and **Down** arrow keys held down → Display: **Parameter increases or decreases.**
SEL pressed → Display: **Parameter memorised.**
Display: **P01 or P15**

Up and **Down** arrow keys held down → Display: **EPr** until the buttons are released.

For programming purposes, other than the memorised values, the current values are also updated.
This does not include the *Manual/Automatic* mode, which will be effective only after the next time the control unit is turned on again, in order to avoid unwanted charge commutations.

The relay intervention sequence is as follows:

Supposing that:

- **P18 is set at 0 (factory setting), reconnection disabled**
- **P19 is set at 1 (factory setting), relay off on alarm on**
- **P20 is set at 1 (factory setting), acquisition of LR and LG signals**

With Network OK:

- Relay RL1 Network charge = ON (TR contact closed)
- Relay RL2 Man/Aut = OFF (relay inside the module)
- Relay RL3 Generator charge = OFF (TG contact open)
- Relay RL4 start generator = OFF (SG contact open)
- Relay RL5 Alarm = OFF (Alarm contact open)

With Network KO, after P07 time:

- Relay RL4 start generator = ON (SG contact closed)

With Network KO after time P07s + P08s + P09s:

- Relay RL1 Network charge = OFF (TR contact open)
- Software interlock 500 ms.
- Relay RL3 Generator charge = ON (TG contact closed)

With generator OK, after P10s that Network is OK:

- Relay RL3 Generator charge = OFF (TG contact open)
- Interlock 500 ms.
- Relay RL1 Network charge = ON (TR contact closed)

With generator OK, Network OK, after P11s that charge has been re-commutated:

- Relay RL4 start generator = OFF (SG contact open)

With Network KO after time P07s + P08s + P09s and Generator KO:

Relay RL1 Network charge	= OFF (TR contact open)
Relay RL3 Generator charge	= OFF (TG contact open)
Relay RL5 Alarm	= ON (Alarm contact closed)

ALARM LAG TIME

The control unit must monitor up to 6 voltages, 3 for the Network and 3 for the Generator.

To read each phase voltage with sufficient stability, it takes 300 ms.

The complete scanning of the Network phases therefore takes place in about 1 second. Subsequently the absent phase alarm may have a delay of up to 1 second.

For the lag time on the network voltage return signal, the times double.

In this mode, in fact, all 6 phases are monitored, therefore the maximum lag time is about 2 seconds.

ER1 ER2 ER3 ER4 ALARMS

Alarm **ER1** voltage

Alarm **ER2** frequency

Alarm **ER3** commutation remote control switch control

Alarm **ER4** phase symmetry

In any of these alarm conditions, relay RL5 follows the trend on the basis of the parameters set in **P19**.

The intervention of the **Er** alarms is defined in parameter **P18**, which, if disabled (**0**), does not lead to the commutation of the charge relays, but only to the shutdown of the Generator start-up relays.

Only subsequently, when the alarm is cancelled by means of the **AUT** button, the charge commutation relays are restored to the "charge on Network" configuration.

If enabled (**1**) and the Generator happens to not be within the set parameters, when the error occurs, the charge on the Network will be re-enabled.

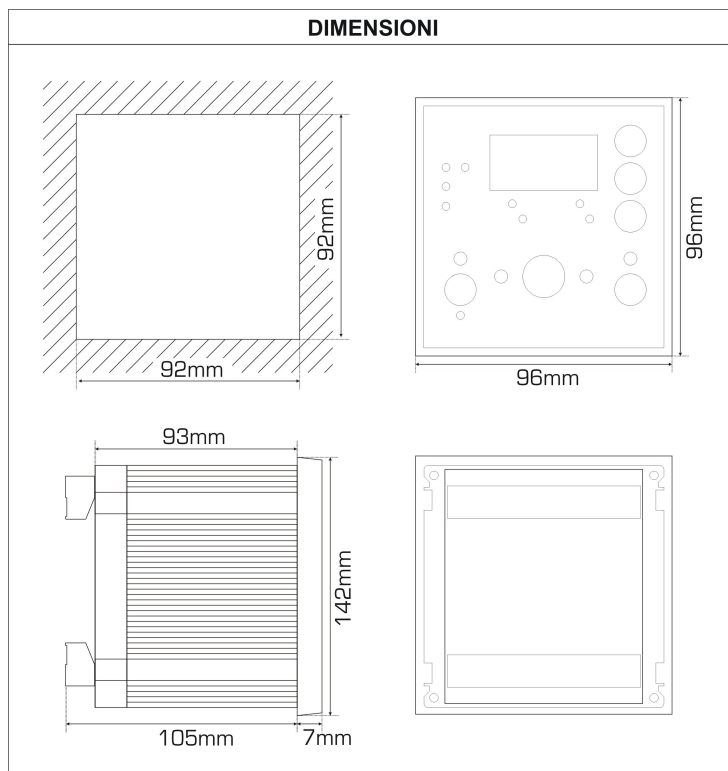
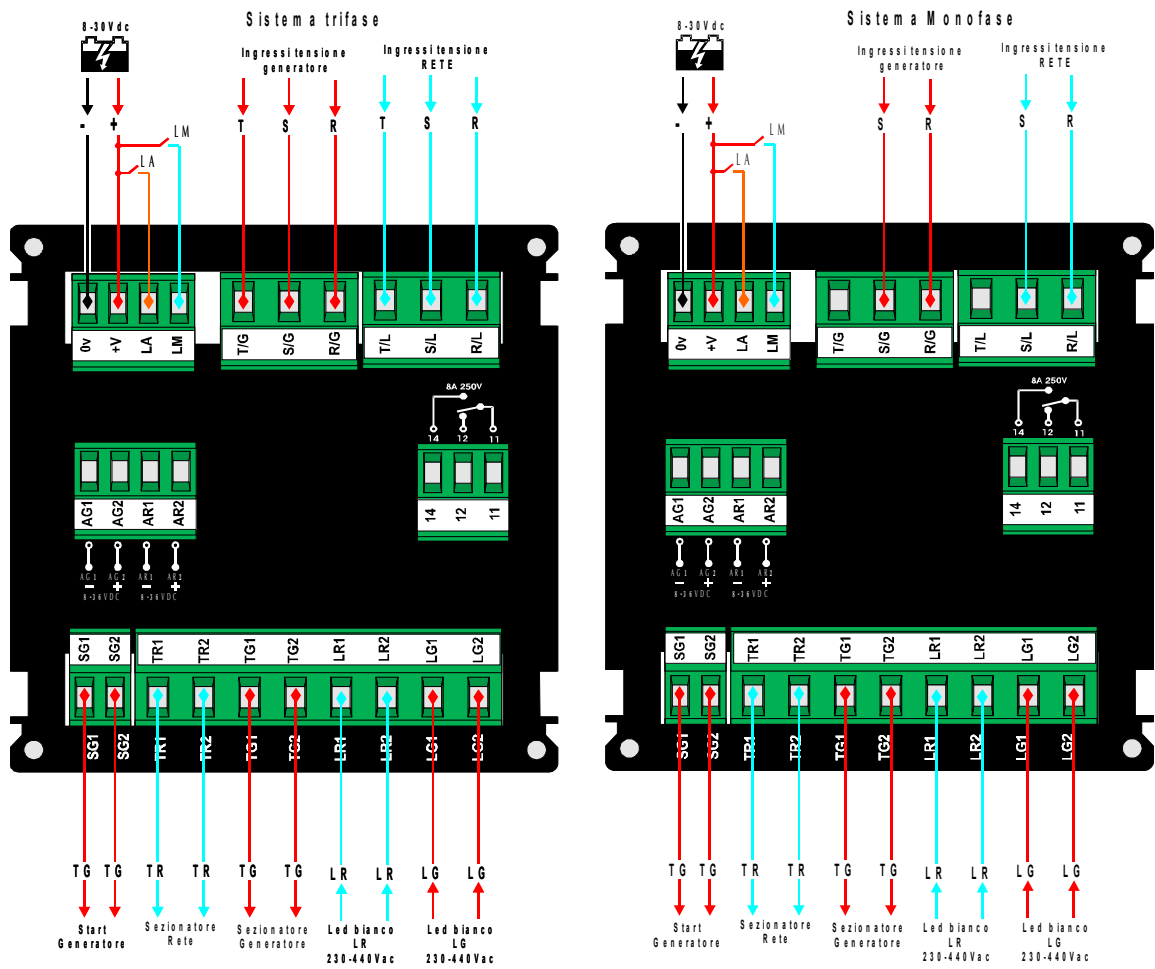

Dimensions

